

Industrial Heat Exchangers

Preheating • Heat recovery • Heating • Cooling • Condensing

Flue gas/ Air up to 350 °C • Design Pressure up to 26 bar(g)



Backed by more than 50 years' experience, and as one of the leading and recognized manufacturers in Denmark, Boilerworks can offer heat exchangers for industrial processes and power/heat generating plants for:

- Preheating
- Heating
- Heat recovery
- Condensing
- Cooling

The exchangers are dimensioned to customers' individual requirements. Boilerworks will perform the thermal calculations to energy optimize the exchangers. All materials are selected to match the current media.

Nearly all types of production process generate excess heat. This heat can be utilized if purpose-designed heat exchangers are used.

Typical applications may include:

- District heating plants
- Processing industries
- Chemical industries
- Food-processing industries
- Waste to heat plants
- Oil refineries
- Biomass plants



Mini economizer for bakeries or similar small enterprises generating waste heat.



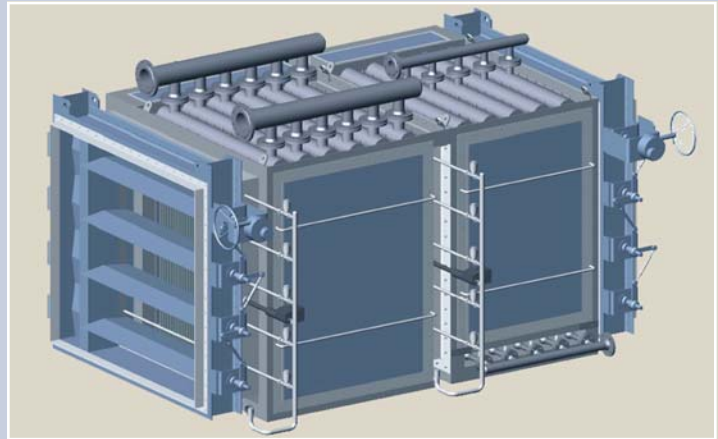
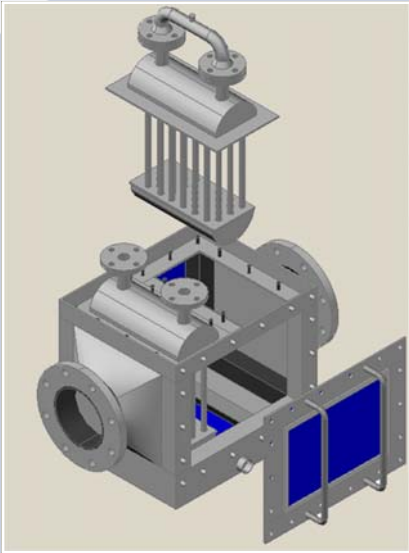

Customer benefits:

- Customized design matching requirements and space
- Customized modular heating surface
- Material selection matching operating conditions
- Short lead times
- Reduced energy consumption, improved environment
- Easy access to cleaning and simple maintenance
- Over 50 years' experience

Typical technical data:

- Design pressure: from 2 to 26 bar(g)
- Water temperature: from 0 to 228 °C
- Flue gas temperature: from 0 to 350 °C

On request the design, even of the connections, can be customized to the plant thus simplifying installation and minimizing on space requirements.

Condensing exchangers:

Cooling flue gasses to below the dew point enables fully condensing operation.

Typically used in district heating plants, where flue gasses do not carry with them Cl or SO_(x) residues, such as, for instance, natural gas or LPG.

Feed water pre-heaters:

A feed water pre-heater upstream of the boiler increases efficiency considerably. Return or feed water for a steam boiler is heated by the flue gasses from the boiler.

Pre-heating or cooling:

Heat exchangers are widely used to pre-heat/cool process air.

The medium may be hot water, steam or for instance cooling water.

The exchangers are often incorporated to pre-heat combustion air, heat process air or they are connected to drying chambers.



“ Boilerworks will customize to individual requirements ”



Boilerworks has specialised in the manufacture and supply of high-pressure boilers and boiler sections for power stations, waste and biomass-fired as well as industrial and petrochemical plants.

Boilerworks has in-depth experience and know-how of panel wall manufacture, tube bending, heat treatment and acid cleaning of high-pressure boiler parts.



Maintenance of boiler plants is one of Boilerworks' specialties. We cover anything from simple repairs to comprehensive maintenance planning, plant modernization, installation of new parts and control systems as well as upgrading.

**Boilerworks offers 24/7 service
HOTLINE: (+45) 30 94 48 70**



At Boilerworks we firmly believe that we must have a common goal - and not a conflict - for economic development and environment-protection, both now and in the coming generations.

At Boilerworks we have drafted our own Environment Charter, based on the Environment Charter of the ICC:

“The Business Charter for Sustainable Development - 16 principles”